

DEDA

TECHNOLOGY

# Introduction

- **Headquarters**

- KU Leuven Innovation & Incubation Center / Leuven, Belgium

- **Primary Areas of Activity**

- **E-mobility;** Electric Powertrain, BMS, EV Charging
- **Power Electronics;** Electric Motor Drives, Battery Converters, Inverters, Traction Converters
- **Grid Modernization;** Residential Energy Systems, Micro Grids, Distribution Automation, V2G & B2G

- **Target Customers**

- Aerospace, Maritime and Automotive Industries
- Research Institutions
- Horizon Europe & Eurogia Projects
- OEM's/Suppliers.

# Our Resolutions

- **HIL-Based Simulation, Testing, and System Validation Services**
  - Hardware-in-the-loop (HIL) testing and validation for e-powertrain systems.
- **Digital Twin Solutions**
  - Modeling virtual twins of e-powertrain systems to accelerate R&D processes, significantly reducing design, testing, and validation costs and contributing to the economy.
- **Power Electronics Engineering**
  - Development of inverters, converters, and battery management systems for Power Electronic systems.
- **R&D and Consulting Services**
  - Developing innovative and sustainable solutions under EU funded projects and providing consultancy services to high-tech firms within the European Union.

# Methodologies

## SIL

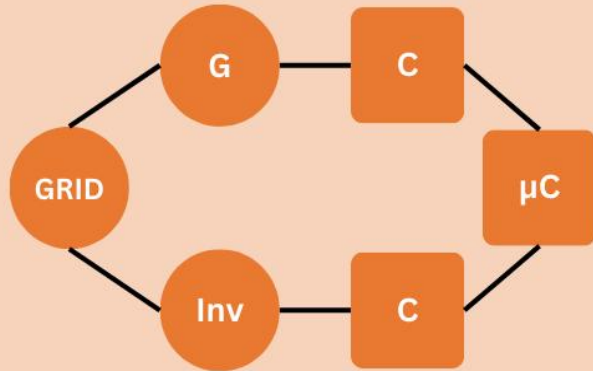

- Modeled in RTS
- No power in the setup
- Mathematical model simulation

## C-HIL

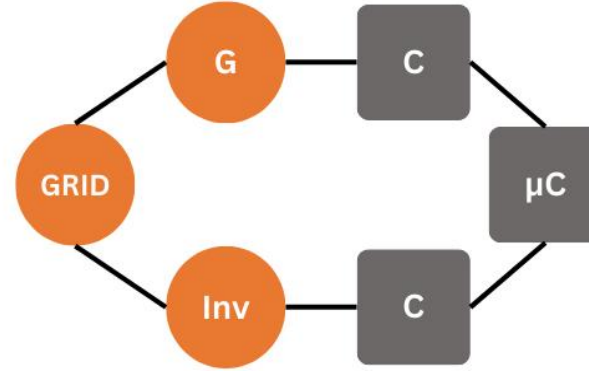

- Modeled in RTS
- No power in the setup
- Low-level voltages ( $\pm 10V$ ) & currents

## P-HIL

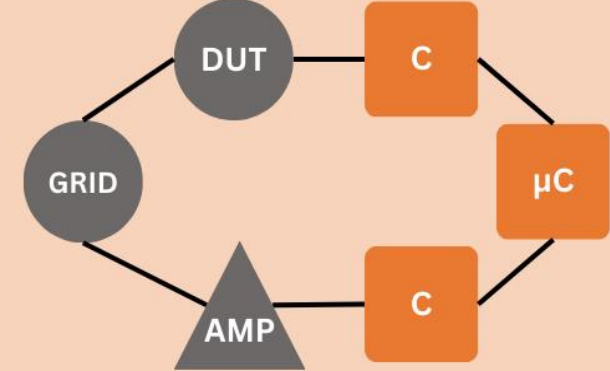

- Partly modeled in RTS
- Power generated via amplifier
- High-level voltages & currents

**RTS:** Real-time simulator

**SIL:** Software in-the-loop

**C-HIL:** Controller Hardware in-the-loop

**P-HIL:** Power Hardware in-the-loop

**DUT:** Power electronics device under test (Inverter/Generator)

**Simulated**



**Real**



# Controller & Power HIL- System Setup

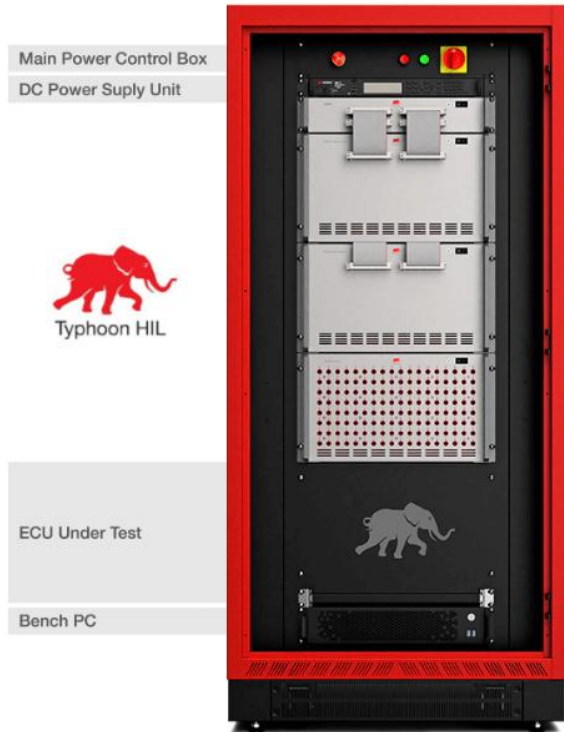

Typhoon HIL-606 System



Power Amplifier XkW



Deda Technology HIL-606 Lab

# Aviation E-Powertrain HIL Testing & Validation

## Hybrid-Electric Aircraft Development



## Multi Purpose Quad-Drone Validation



## Fixed Wing UAV Validation



## Rotating Wing UAV Validation



# Aviation Electric Powertrain

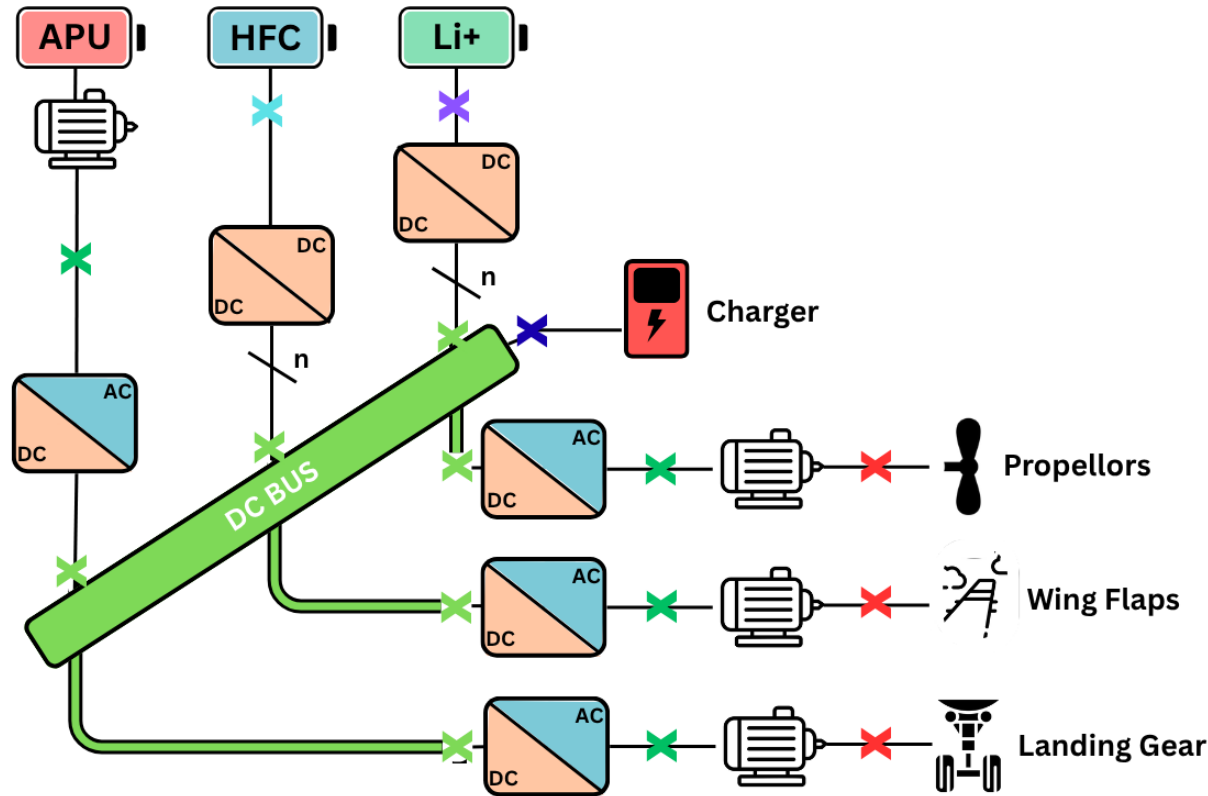

**Power Sources:** Batteries, Fuel Cells, APU's  
**Converters:** DC/DC units (voltage regulation)  
**DC Bus:** Central Power Distribution  
**Inverters:** AC/DC or DC/AC units  
**Electric Motors:** Drive systems for components

**Emulated By HIL**

X Fuel Cell	X Battery
X DC Bus	X AC Power Grid
X E-Motor	X Dyno

# Use Case - E-Motor Inverter Rapid Prototyping

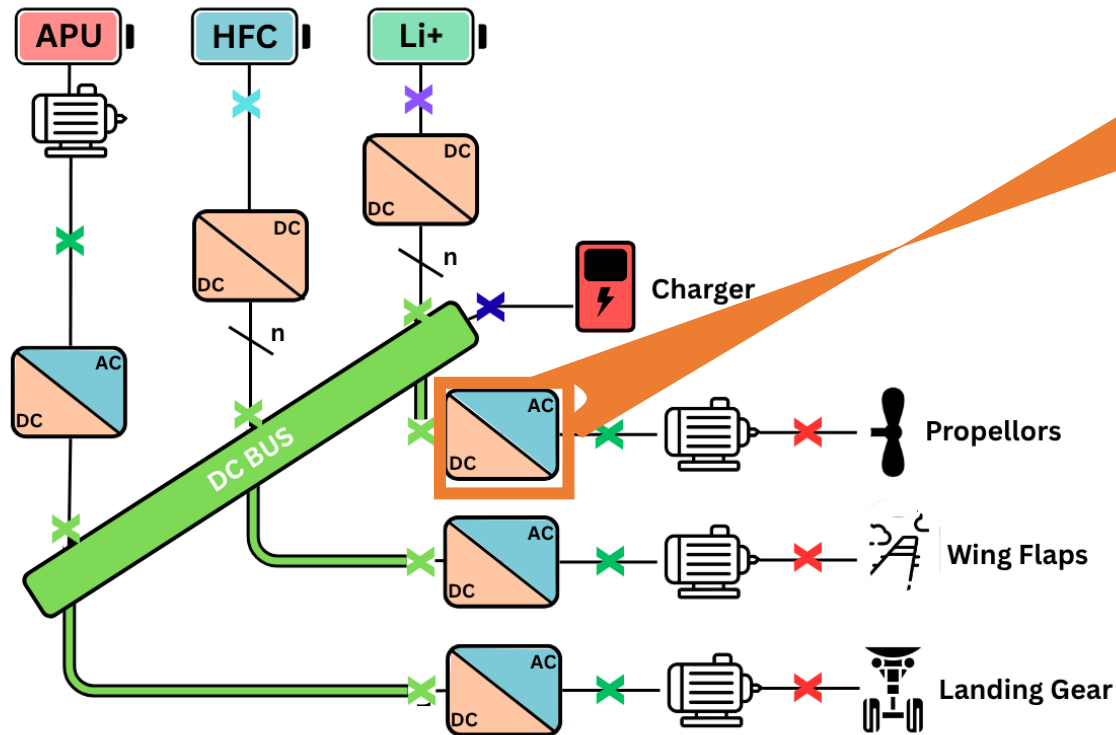

**Pre-condition:**  
DC/AC inverter  
does NOT exist



**Goal:**  
Use Power HIL as an  
inverter to start real  
world tests rapidly

# Grid Automation & Smart Grid Testing

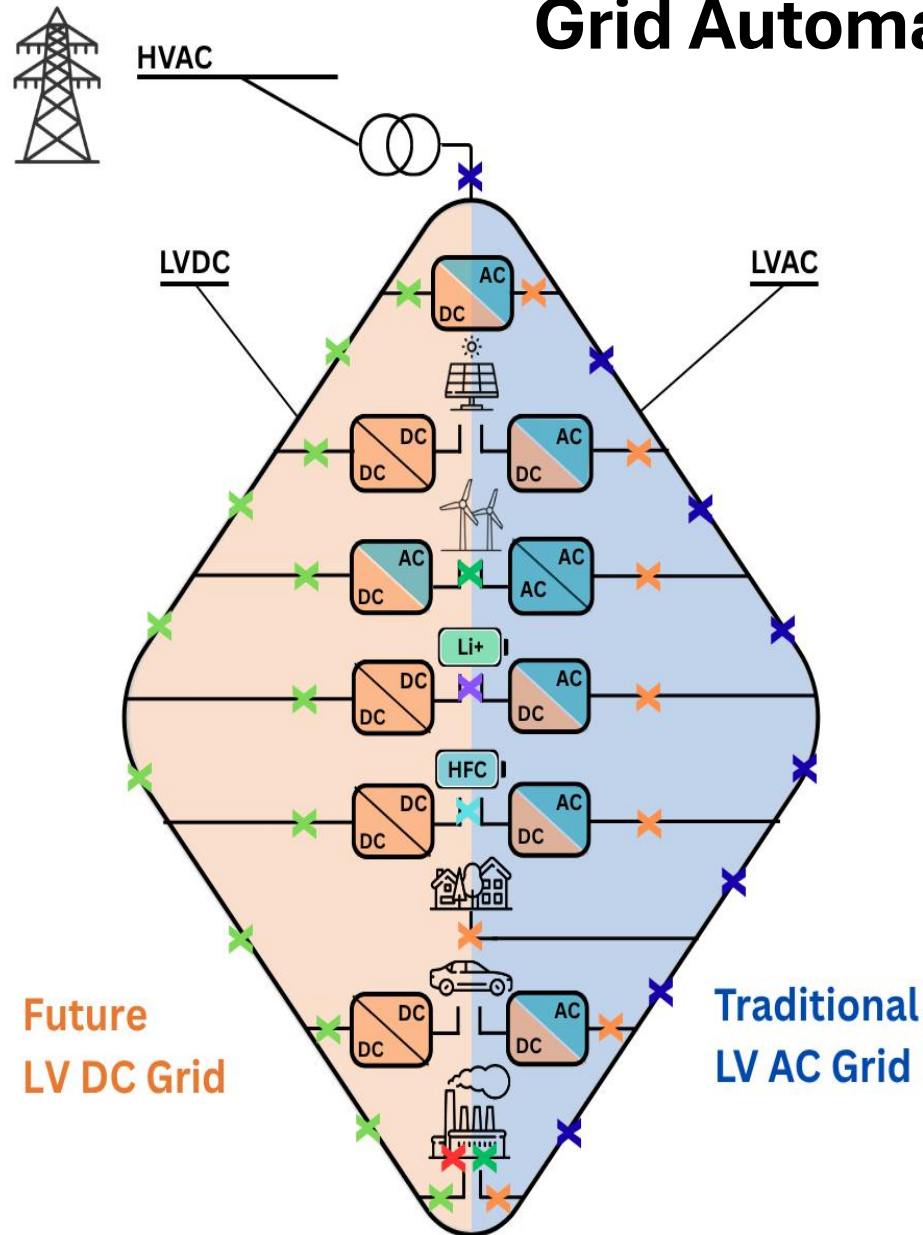

## Grid Modernization includes:

- SCADA systems
- Energy Management Systems (EMS)
- Advanced Distribution Management Systems

## DedaTech via HIL-606 can:

- Emulate grid behavior
- Interface with real controllers
- Test communication delays and failures
- Validate control logic safely

# Conclusion

- ❖ **P-HIL** provides a convenient solution for engineers to incorporate simulated electric power systems into their test, development and verification processes, **eliminating the need for physical hardware**.
- ❖ **Ensure redundancy and reliability** during development, test and verification operations.
- ❖ **Multiuse;**
  - **P-HIL** System can be used as inverter/converter rapid prototyping system.
- ❖ **Multisystem;**
  - **P-HIL** System provides ready to use as AC System, DC System and E-motor System.
- ❖ **HIL** provides testing and validation processes for;
  - Residential energy systems
  - Battery energy storage systems (BESS)
  - Microgrids
  - Distribution automation

# Contact Us



**GSM:**

+32 488 364200

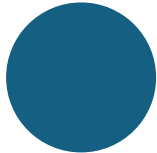

[www.dedatech.be](http://www.dedatech.be)



**Email:**

[selcuk.deda@dedatech.be](mailto:selcuk.deda@dedatech.be)



**Address:**

Deda Technology BV  
I&I Center KU Leuven  
Kapeldreef 60, 3001  
Belgium



Typhoon HIL